

Bg size HA Tamaño mod. SEW	Sachnummer Article no. Numéro d'article Código de pieza Numero codice Wistro	A	AF	B	D	D1	DL	E	L	
132/160	01376993	15.00.1327	213	96	8,5	272	275	265	6,6x10	163
132/160	01861085	15.00.1328	245	128	8,5	272	275	265	6,6x10	163
132/160	01827324	15.00.1326	335	218	8,5	272	275	265	6,6x10	163
132/160	01901605	15.00.1330	372	255	8,5	272	275	265	6,6x10	163
160/180	01877607	15.00.1315	280	140	12	327	331	310	9x12	191
160/180	01877615	15.00.1317	432	292	12	327	331	310	9x12	191
200/225	01877623	15.00.1320	312	161	14	390	394	370	9x12	202
200/225	01877658	15.00.1319	340	189	14	390	394	370	9x12	202
200/225	01877631	15.00.1318	480	329	14	390	394	370	9x12	202
250/280	01868969	15.00.1325	375	215	17,5	506	510	370	9x12	214
250/280	01868977	15.00.1324	530	367	17,5	506	510	370	9x12	214

c	07.07.10	An.	 SIEBERT Elektromaschinenbau GmbH	24.01.0069	
b	neue Nr. andere Haube	24.10.08		Hag.	SEW
a	105 / 95 106 / 96	15.11.07		v.S.	Bg132/160 - Bg250/280
Zust	Änderung	Datum		Name	Erstellt: 03.09.07/vS

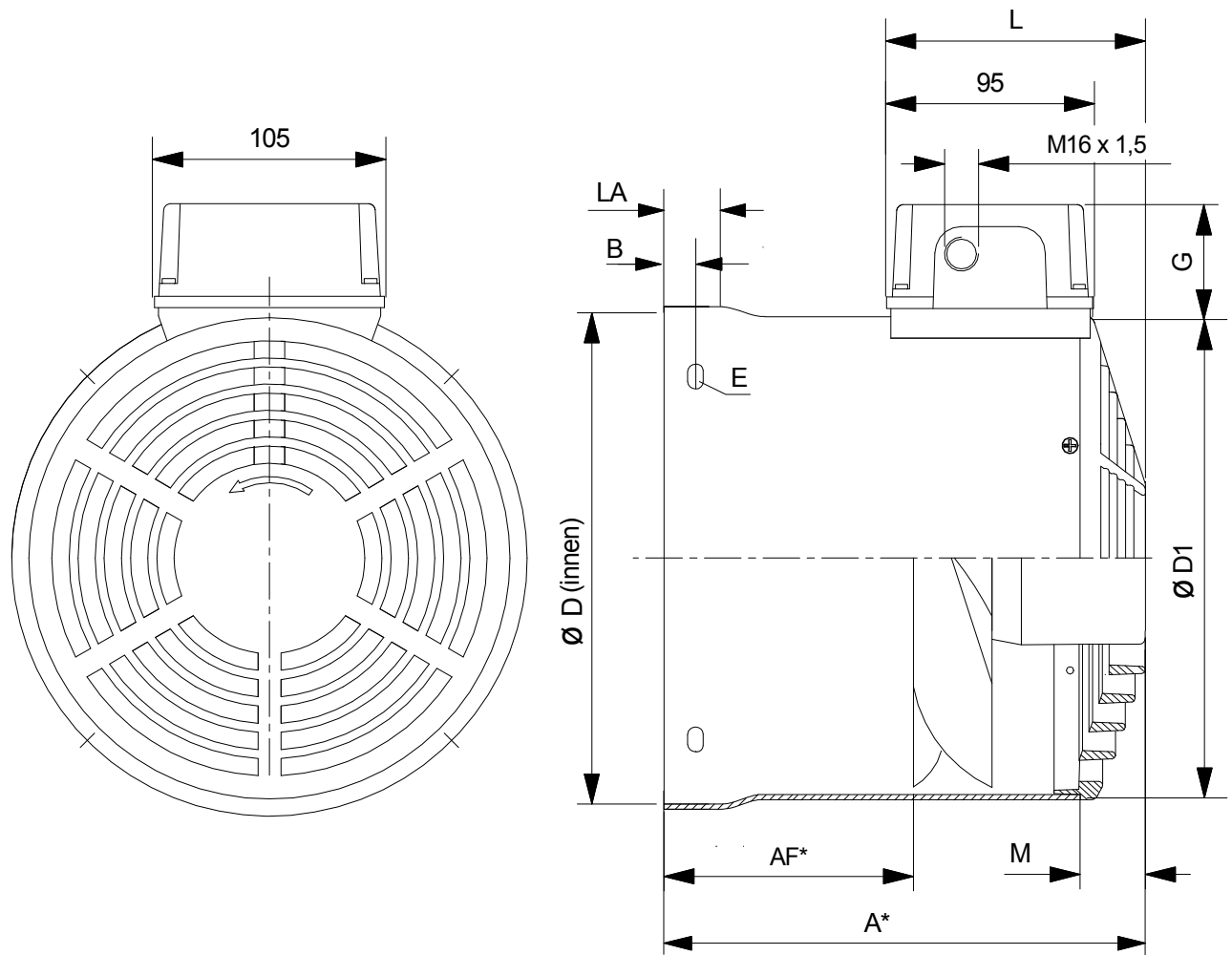

Bg size HA Tamaño mod.		Sachnummer Article no. Numéro d'article Código de pieza Numero codice	A*	AF*	B	D	D 1	E	G	LA	L	M	
SEW	WISTRO												
71/80	(71)	17.00.0000	190	95	7	143	139	5,5 x 7	53	25	107	20	
71/80	(71)	17.00.0132	228	133	7	143	139	5,5 x 7	53	25	107	20	
90/100	(100)	17.01.0129	194	89	9	194	195	5,5 x 7	53	30	117	30	
90/100	(100)	17.01.0128	271	166	9	194	195	5,5 x 7	53	30	117	30	
90/100	(100)	17.01.0130	343	238	9	194	195	5,5 x 7	53	30	117	30	
112/132S	(112)	17.01.0070	195	90	8	218	219	5,5 x 7	53	40	117	30	
112/132S	(112)	17.01.0127	282	177	8	218	219	5,5 x 7	53	40	117	30	
112/132S	(112)	17.01.0131	365	260	8	218	219	5,5 x 7	53	40	117	30	
132M/160M	(132)	17.00.0443	236	109	8,5	272	258	6,6 x 8	54	68	127	40	
132M/160M	(132)	17.00.0444	268	141	8,5	272	258	6,6 x 8	54	100	127	40	
132M/160M	(132)	17.00.0439	358	231	8,5	272	258	6,6 x 8	54	190	127	40	

* Standardausführung, andere Längen nach Kundenspezifikation möglich

* Standard version, different length available

* Version standard, différentes spécifications disponibles

* Aplicación estándar, posibilidad de otras longitudes según las especificaciones del cliente

* Versione standard, altre lunghezze possibili in base alle specifiche dei clienti

b	Anpassung n.Motor	07.12.09	Mar		24.14.0067 SEW Bg71/80 IL - Bg132M/160M IL
a	Volumenst. entfernt	23.10.09	Mar		
	neue Zeichnung	27.08.03	Fab.		
Zust.	Änderung	Datum	Name		