

Bg size HA Tamaño mod.		Sachnummer Article no. Numéro d'article Código de pieza Numero codice	A*	AF*	B	D	D 1	E	F	G	LA	L	M
VEM	WISTRO												
132 S 132 M6,8 132 SX2	(112)	17.01.0059	235	130	15	234	219	6,6 x 8	109	53	30	117	30
132 M4, MX6 160 M 160 MX8	(132)	17.00.0184	260	133	27	278	258	6,6 x 8	129	54	40	127	40
160 L 160 MX2 180 M4 180 L6,8	(160)	17.00.0175	310	158	27	338	311	6,6 x 8	157	54	40	127	40
180 M2 180 L4 200 L 200LX6	(200)	17.00.0176	315	163	26	382	311	6,6 x 8	174	54	40	127	40

- * Standardausführung, andere Längen nach Kundenspezifikation möglich
- * Standard version, different length available
- * Version standard, différentes spécifications disponibles
- * Aplicación estándar, posibilidad de otras longitudes según las especificaciones del cliente
- * Versione standard, altre lunghezze possibili in base alle specifiche dei clienti

b	Anpassung n.Motor	07.12.09	Mar	 SIEBERT Elektromaschinenbau GmbH	24.15.0067 VEM K21R Bg112 IL - Bg200 IL
a	Volumenst. entfernt	23.10.09	Mar		
	neue Zeichnung	06.06.06	Fab.		
Zust.	Änderung	Datum	Name		

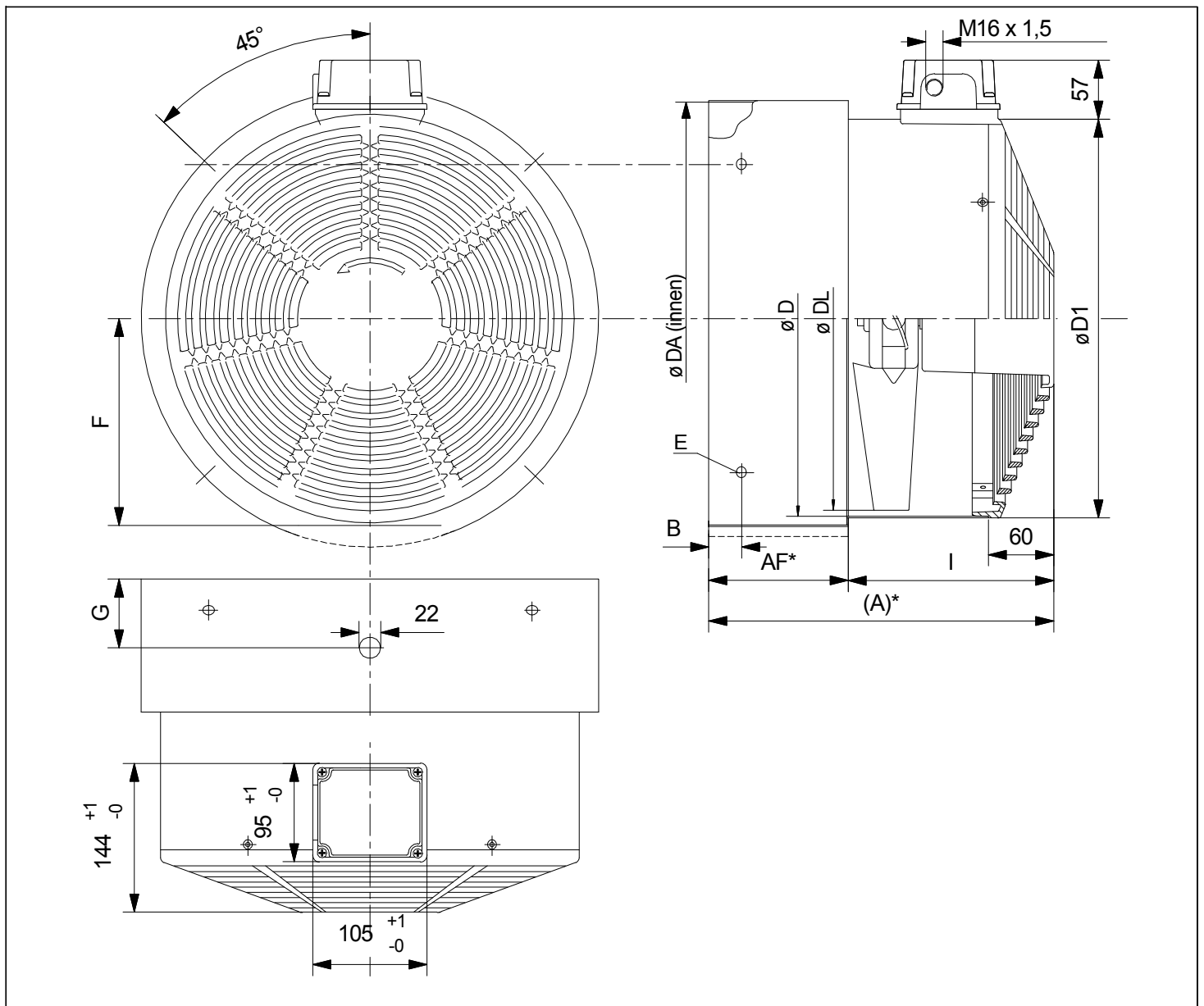

Bg size HA Tamaño mod.	Sachnummer Article no. Numéro d'article Código de pieza Numero codice	A*	AF*	B	D	DA	D1	DL	E	F	G	I
VEM												
200 LX2 225 S4 (8), M2 (4,6,8)	17.00.0993	357	162	29	382	421	385	375	6,6x8	193	—	195
250 M2 (4,6,8)	17.00.1022	374	179	33	382	477	385	375	9x12	218	—	195
280 S2 (4,6,8) M2 (4,6,8)	17.00.1068	411	216	35	382	536	385	375	9x12	245	—	195
280 S2 (4,6,8) M2 (4,6,8)	17.00.1024	416	216	35	477	536	480	470	9x12	245	—	200
315 S2 (4,6,8) M2 (4,6,8)	17.00.1025	419	219	38	477	605	480	470	9x12	270	64	200
315 MY2 (4,6,8) L2 (4,6,8)	17.00.0997	419	219	50	477	670	480	470	9x12	305	68	200
355	17.00.1026	600	400	50	477	764	480	470	9x12	345	68+188	200

* Standardausführung, andere Längen nach Kundenspezifikation möglich

* Standard version, different length available

* Version standard, différent spécifications disponibles

* Aplicación estándar, posibilidad de otras longitudes según las especificaciones del cliente

* Versione standard, altre lunghezze possibili in base alle specifiche dei clienti

b	Volumenst. entfernt	23.10.09	Mar		24.01.0122 FLAI Bg204 - Bg355 VEM
a	Volumenstrom ergänzt	02.11.06	Fab.		
Zust.	Änderung	Datum	Name		

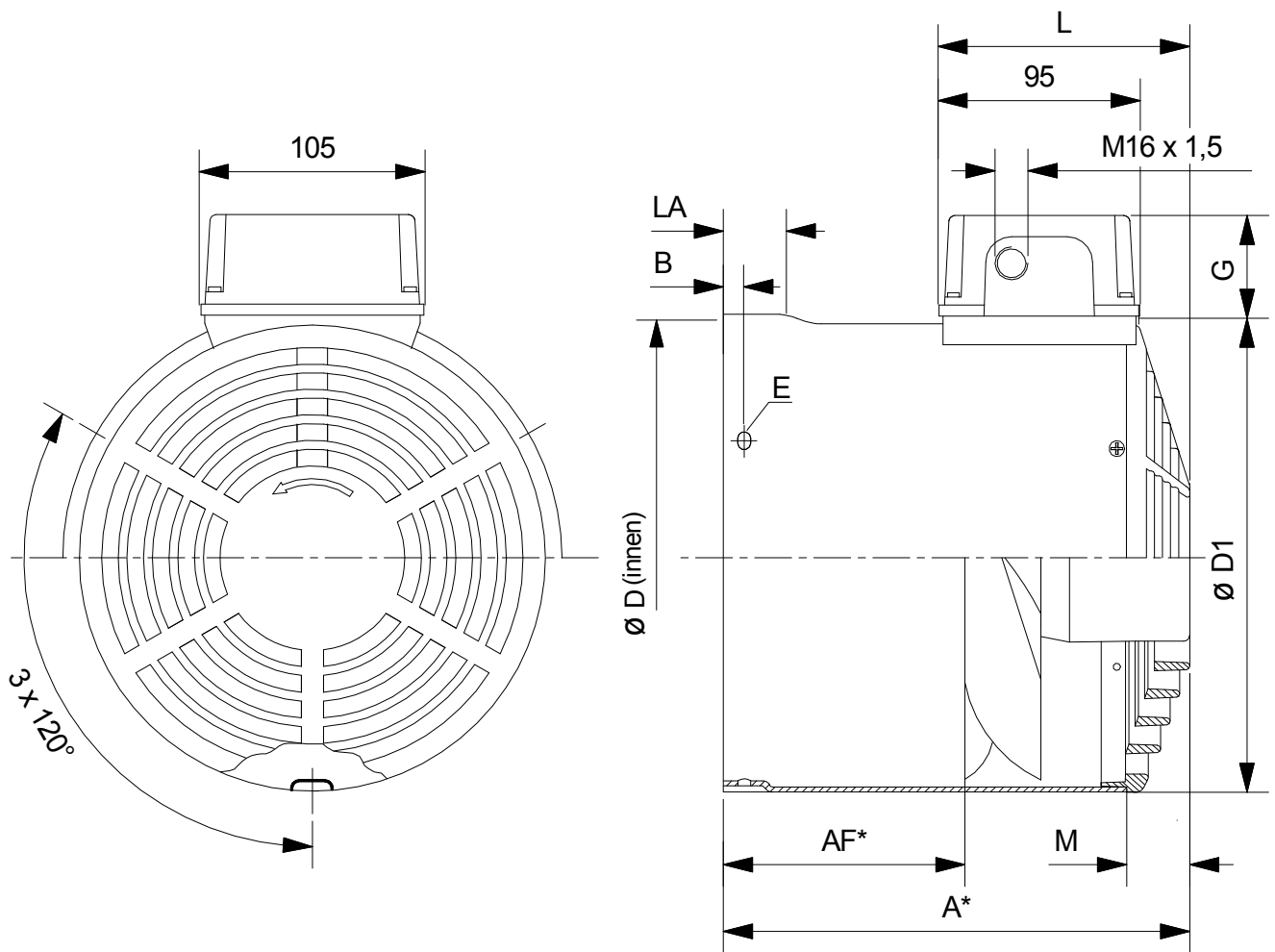

Bg size HA Tamaño mod.	Sachnummer Article no. Numéro d'article Código de pieza Numero codice	A*	AF*	B	D	D 1	E	G	LA	L	M	
VEM	WISTRO											
63	(63)	17.00.0053	133	38	6	114	124	4,3x6	53	—	107	20
71	(63)	17.00.0025	146	51	6	127	124	4,3x6	53	20	107	20
80	(71)	17.00.0007	160	65	8	143	139	4,3x6	53	25	107	20
90	(80)	17.00.0024	161	66	8	160	157	4,3x6	53	25	107	20
100	(90)	17.01.0026	179	74	9	180	177	5,5x7	53	25	117	30
100LX 112	(100)	17.01.0027	180	75	9	200	195	5,5x7	53	25	117	30

- * Standardausführung, andere Längen nach Kundenspezifikation möglich
- * Standard version, different length available
- * Version standard, différentes spécifications disponibles
- * Aplicación estándar, posibilidad de otras longitudes según las especificaciones del cliente
- * Versione standard, altre lunghezze possibili in base alle specifiche dei clienti

b	Anpassung n.Motor	07.12.09	Mar	 Elektromaschinenbau GmbH	24.02.0067 VEM K21R Bg63 IL - Bg112 IL
a	Volumenst. entfernt	23.10.09	Mar		
	neue Zeichng.	09.10.02	Fab		
Zust.	Änderung	Datum	Name		